

BASED ON BS.8888

DO NOT SCALE IF IN DOUBT ASK

DIMENSIONS IN MILLIMETRES
(INCHES)

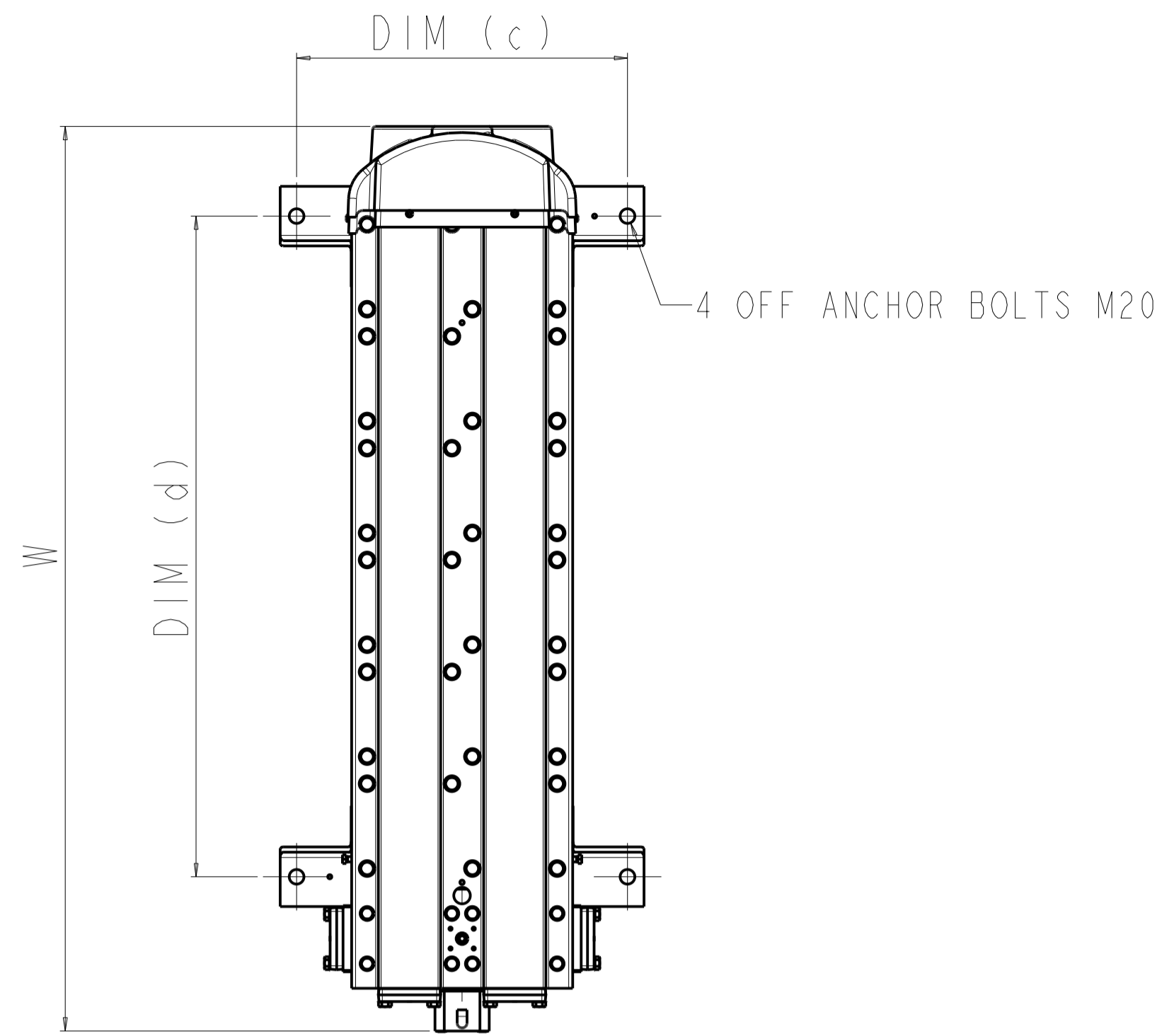

MODEL	Pipe Size	Height (H)		Width (W)		Depth (D)		Dim (a)		Dim (b)		Dim (c)		Dim (d)		Weight	
		mm	ins	mm	ins	mm	ins	mm	ins	mm	ins	mm	ins	mm	ins	kg	lbs
MXS/DS102C	2"	1647	64.8	686.5	27.0	550	21.7	360.5	14.2	1461	57.5	500	19.7	322	12.7	235	518
MXS/DS103C	2"	1647	64.8	855.5	33.7	550	21.7	360.5	14.2	1461	57.5	500	19.7	491	19.3	316	696
MXS/DS103	2"	1892	74.5	855.5	33.7	550	21.7	360.5	14.2	1706	67.2	500	19.7	491	19.3	355	782
MXS/DS104	2"	1892	74.5	1024.5	40.3	550	21.7	360.5	14.2	1706	67.2	500	19.7	660	26.0	450	992
MXS/DS105	2 1/2"	1892	74.5	1193.5	47.0	550	21.7	360.5	14.2	1706	67.2	500	19.7	829	32.6	543	1197
MXS/DS106	2 1/2"	1892	74.5	1362.5	53.6	550	21.7	360.5	14.2	1706	67.2	500	19.7	998	39.3	637	1404
MXS/DS107	2 1/2"	1892	74.5	1531.5	60.3	550	21.7	360.5	14.2	1706	67.2	500	19.7	1167	45.9	731	1611
MXS/DS108	2 1/2"	1892	74.5	1700.5	67.0	550	21.7	360.5	14.2	1706	67.2	500	19.7	1336	52.6	825	1818
MXS/DS109	2 1/2"	1892	74.5	1869.5	73.6	550	21.7	360.5	14.2	1706	67.2	500	19.7	1505	59.3	919	2027
MXS/DS110	2 1/2"	1892	74.5	2038.5	80.3	550	21.7	360.5	14.2	1706	67.2	500	19.7	1674	65.9	1013	2235

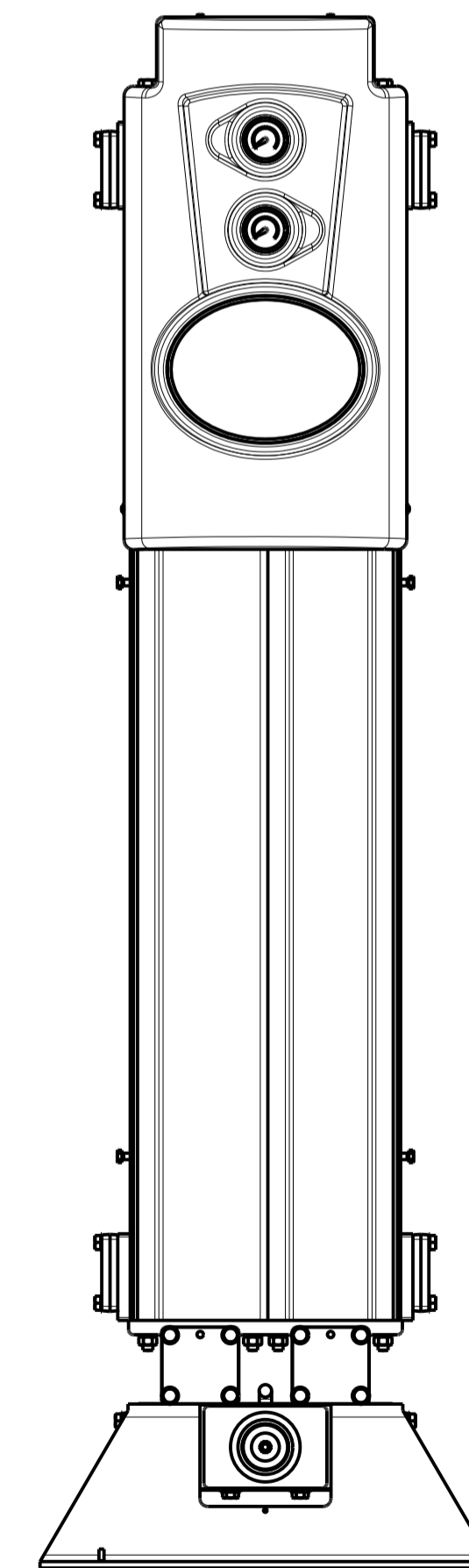
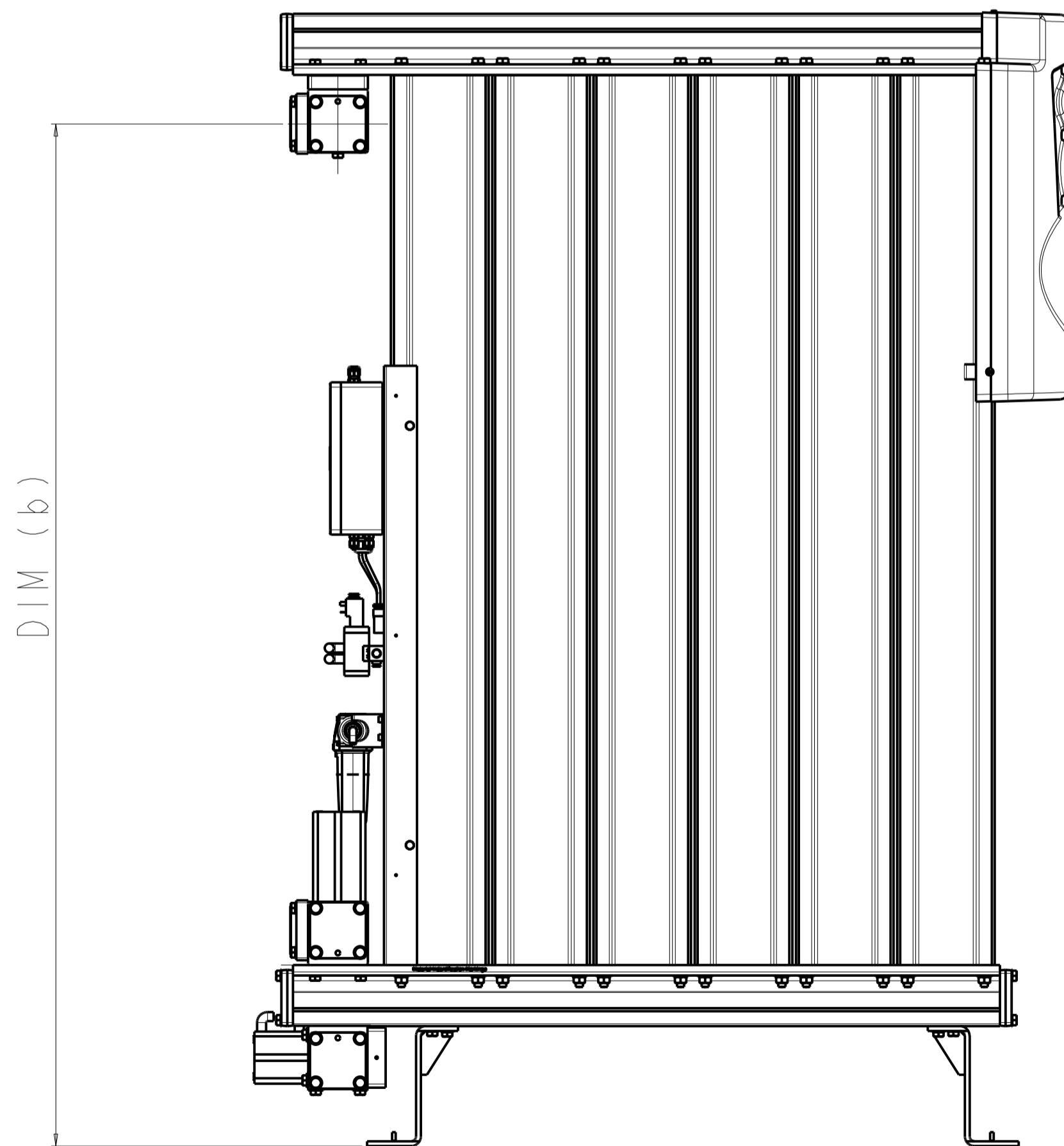
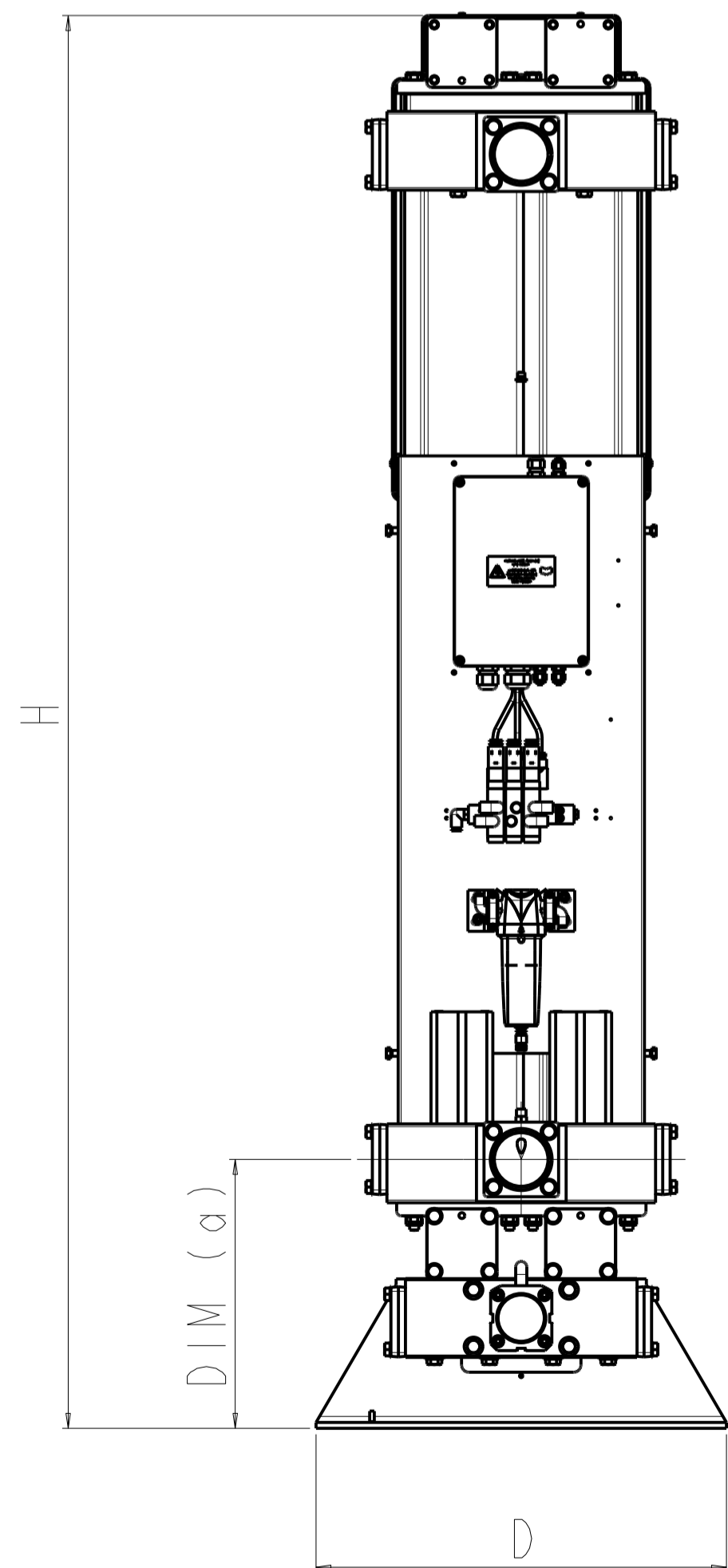

GENERAL TOLERANCES UNLESS OTHERWISE STATED

MACHINED DIMENSIONS
 .XX ±0.13 UP TO 300 ±0.3
 .X ±0.25 OVER 300 TO 600 ±0.5

POSITIONAL TOLERANCE
 PLAIN HOLES ±0.13
 TAPPED HOLES ±0.26
 CONCENTRICITY TOLERANCE 0.13 TIR

MACHINED SURFACES INDICATED THUS
 SURFACE TEXTURE TO BS 1134
 VALUES IN MICROMETRES

ANGLES ±1/2° (EXCEPT CHAMFERS)

METRIC THREADS TO BS 3643 MED. CLASS
 EXTERNAL 6g INTERNAL 6h
 PIPE THREADS
 PRESSURE TIGHT TO BS 21

SHEET METALWORK & FABRICATIONS
 SHEET METALWORK DIMENSIONS
 UP TO 500 ±0.5
 OVER 500 TO 1000 ±1.0
 OVER 1000 ±1.5

FABRICATED PARTS DIMENSIONS
 UP TO 500 ±1
 OVER 500 TO 1000 ±1.5
 OVER 1000 ±2

POSITIONAL TOLERANCE FOR PLAIN & TAPPED HOLES
 UP TO 500 ±0.13
 OVER 500 ±0.25

REV	ECO No.	DATE	NAME
H	0299746	14Aug2019	GT
7	61219	30Jun2008	AWH
6	61242	30Apr2008	AWH
5	54123	8Feb2005	MG
4	54104	7Feb2006	MG

Parker **domnick hunter**
 PARKER HANNIFIN LTD
 domnick hunter DIVISION
 DUKEWAY, TEAM VALLEY TRADING ESTATE
 GATESHEAD, TYNE & WEAR
 ENGLAND, NE11 0PZ
 TEL +44 (0)191 402 9000
 FAX +44 (0)191 482 6296
 www.domnickhunter.com

THIS DOCUMENT IS COPYRIGHT AND IS THE PROPERTY OF PARKER HANNIFIN LTD. IT MUST NOT BE COPIED IN WHOLE OR PART, USED FOR MANUFACTURE OF, OR OTHERWISE DISCLOSED WITHOUT PRIOR WRITTEN CONSENT OF THE COMPANY

PDM DATABASE =

MATERIAL GEN. ARR.

SCALE 0.125

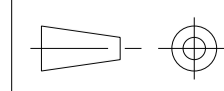

NAME	DRAWN	CHECKED	APPROVED	TITLE
LW	KRS	TK		MX DRYER OVERALL DIM
DATE	25-Jan-04	27-Jan-04	24-Mar-04	

DRG. No 101-8461 SHEET 1 of 1

Model No: 101-8461